

Diaphragm

This type of actuator is used exclusively for rotary valves. The edge of the diaphragm is free, and by attaching a link, the linear motion of the actuator is converted to a smooth rotational motion in the valve stem. Diaphragm features friction-free operation, excellent efficiency, and high output.



Diaphragm Specifications		
Type	280H	400HP
Structure	Floating system	
Diaphragm area (cm ²)	350	725
Max. supply pressure (KPa)	280	
Spring range (KPa)	60 to 220	80 to 200
Max. stroke (mm)	40.8	58.3
Applicable valve size (kg)	28.0 (Without top handle) (including bracket)	57.1 (Without top handle) (including bracket)

Remark: For both types 280 and 400, the manual handle (top handle) is available as an option.

Diaphragm Operation principle

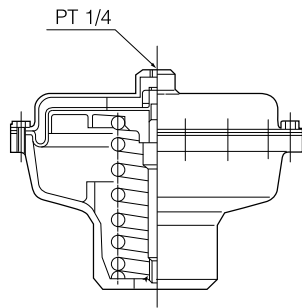

This type is exclusively used for rotary valves. The nose of the diaphragm is free, and by attaching a link, linear motion of the actuator is smoothly converted to rotational motion of the valve stem. Diaphragm features friction-free operation, excellent efficiency, and high output.

Actuator
New ELMY 41
New MICON ELMY II 41
PMK-SRF 4K
SRJ 4J
LTKD 4L
New T-DYNAMO 7E/7F/7G
TGA 3A
TG-S 3K/3U
3C
Diaphragm 6X/6W/6Z/6A/6B
Hydraulic cylinder 3H
Manual Actuators 17/1J/2U/2I/2S/2G/2R